

版本 REV.	日期 DATE	ECN NO.	变更内容 DESCRIPTION	制图 DRAWN

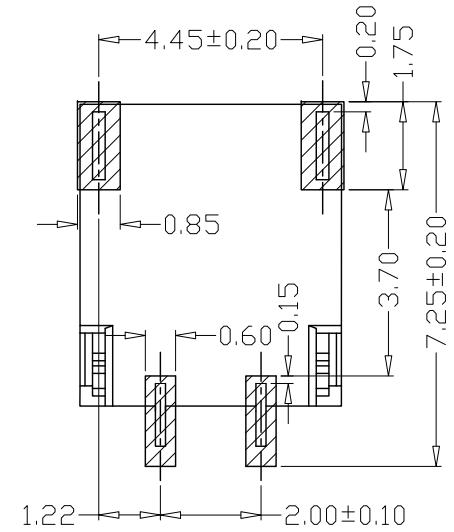

PCB LAYOUT

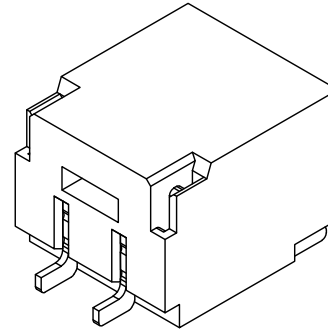
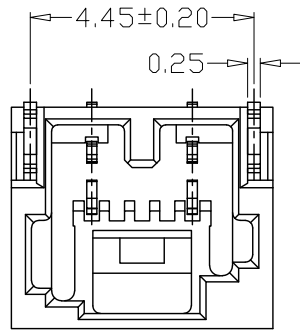
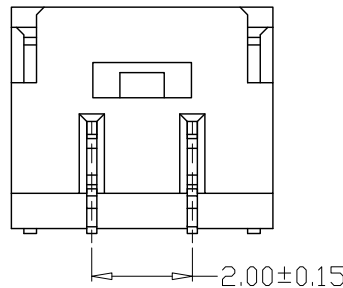
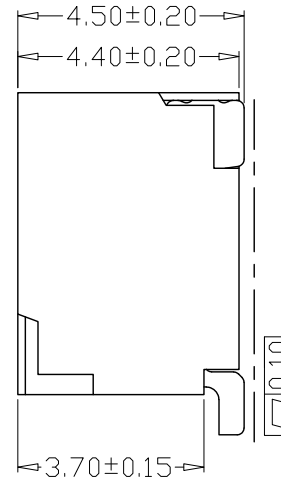
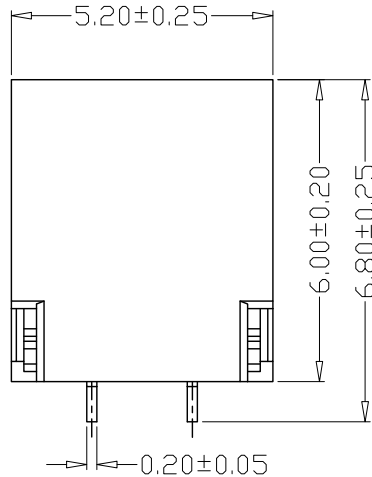

SPECIFICATIONS

- Current Rating: 1A AC, DC
- Voltage Rating: 250V AC, DC
- Temperatuer Range: -25°C~+130°C
- Contact Resistance: 30mΩ Max
- Insulation Resistance: 1000MΩ Min
- Withstanding Voltang: 1000V AC/minute
- Material

Wafer: LCP UL94V-0

PIN: Phosphoric bronze Tin-plated

Solder tab: Phosphoric bronze Tin-plated

GENEAL TOLERANCE		制图 Mapping	张迎春 2022、09、12	料号 PART NO.	B20002-02AWB	版本 REV.	A
X.±0.25	X.°±2°	审核 Audit	钱岳生 2022、09、12	品名 TITLE	20026卧贴 WAFER SMT TYPE	页次 SHEET	1/1
.X±0.25	.X°±1°			客户料号 CUTM. NO.			
.XX±0.15	.XX°±0.5°	核准 Approved	张名 2022、09、13	乐清市宏一电子有限公司 Yueqing HongYi Electronics Co., Ltd			
.XXX±0.10	.XXX°±0.5°	单位 Units	MM				